

# Enhancement of Grid Connected Four Leg PV Inverter Using Adaptive Neuro Fuzzy Interface System

**Masapalli Asha, V. E. Sowjanya**

M.tech Student (PE), Department of EEE, Annamacharya Institute of Technology and Sciences, Tirupati  
Email: masapalliasha@gmail.com

Assistant Professor, Department of EEE, Annamacharya Institute of Technology and Sciences, Tirupati  
Email: esthersowjanya@gmail.com

**ABSTRACT:** A grid supportive two-stage three-phase three-wire SPV (Solar Photovoltaic) system with ANFIS controller is presented in this paper, wherein a boost converter is used as a first stage to serve the function of MPPT (Maximum Power Point Tracking) and a 3-leg VSC (Voltage Source Converter) is used to feed the extracted SPV energy along with supporting distribution system for improvement in the power quality. The harmonics elimination, grid currents balancing and compensation for non-active part of the load currents are extra features offered by proposed system other than conventional features of the solar inverter. The true power reflecting part of load current is estimated using an improved adjustable step adaptive neuron based control approach. The output of which is current component reflected on grid side to instantaneously regulate the DC link voltage. In the proposed approach, the load, PV array and loss contributions are kept decoupled. The feasibility of proposed control algorithm is confirmed via MATLAB/SIMULINK results.

**Keywords— ANFIS, Solar PV; Two-stage; Power Quality; MPPT.**

## I INTRODUCTION

The electricity can be considered as one of the primary needs for human beings. The demand for electricity is increasing day by day. However, the conventional fuels for generation of electricity are getting depleted. Moreover, the environmental pollution is also a prime concern. Therefore, renewable energy based systems are getting importance. Solar thermal, SPV (Solar Photovoltaic), wind power generations are few such renewable

energy systems. The SPV is gaining importance as it is reaching the grid parity [1]-[2].

Grid connected solar PV (Photovoltaic) systems do not require a battery energy storage hence these systems are gaining more popularity. Several researchers have proposed grid connected PV inverters [3]-[6]. These systems collect power from solar panel and feed that power into the grid without any big energy storage. A review of topologies for single phase converters is shown in [3]. A single stage topology based PV inverter for grid tied application is shown in [4]. A current source inverter based transformer less PV inverter is proposed in [5], wherein a 4-leg CSI (Current Source Inverter) is proposed for reduction of ground leakage current.

The solar PV characteristics are nonlinear due to which the peak power can be extracted only at a unique voltage from a given PV array. A classification of MPPT (Maximum Power Point Tracking) techniques is presented in [6]. An evaluation of P&O (Perturb and Observe) based MPPT technique is shown in [7]. The P&O based technique is simple and easy to implement, however, it has drawbacks of poor dynamic response and oscillation near MPP point in steady state conditions. An INC (Incremental Conductance) based MPPT technique is used in [8], which is used in here also, as it offers simple and easy to implement structure along with fast dynamic response and high steady state accuracy.

The nonlinear loads using power electronic converter at front-end are getting popular day by day as they offer high efficiency and occupy comparatively low space. However, the harmonics drawn by these systems cause several problems in the distribution

system such as derating of transformer, higher distribution losses and distortion of CCP (Common Connection Point) voltage. The D-STATCOM (Distribution Static Compensator) offers a retrofit solution for these power quality problems [9]-[10]. A peak detection and low pass filter based control algorithm is presented in [9]. An adaptive neural network based technique is used in [10], wherein constant learning rate is used.

The grid supportive solar PV generation systems are demonstrated in [11]-[13]. An algorithm shifting true power component to DC for a multifunctional PV generation system is presented in [11]. However, no experimental results are shown in [11]. The grid tied PV generation system under voltage power quality disturbances is shown in [12]-[15]. An ILST (Improved Linear Sinusoidal Tracer) based control approach for single-stage dual functional system is presented in [16]. However, the frequency response for ILST approach shows that the performance of the control approach deviates under frequency disturbances. Considering this nonstationary behavior with respect to frequency variations an adaptive frequency based approach is presented in [17]. However, in proposed approach, separate frequency estimation is avoided by use of grid voltage unit vectors.

A survey for application of neural network based technique for active filtering is shown in [18]. A variable step size based adaptive harmonics detecting algorithm is used for shunt active filter in [19]-[20]. A control of DSTATCOM with adjustable step least mean square based algorithm is shown in [21]. However, in this paper an improved adjustable step adaptive neuron based control approach is used for grid supportive PV generation system. The proposed control algorithm is called an improved adjustable step neuron adaptive approach as it gives a decoupled estimation of load, loss and solar power contribution. Moreover, the quick response to sudden variation in insolation is managed via a feed-forward term considering active power changes from PV array which ensures a relieved burden on DC link PIC (Proportional Integral Controller). Therefore, the scope of the presented work are as follows.

1. A decoupled estimation of salient true power reflective components of grid current.

2. A suitable improvement is proposed in the exiting D-STATCOM algorithm to make it suitable for combined operation of distributed generation and power quality improvements.
3. Demonstration of effect of separate PV power contribution.
4. A case study for reduction in distribution losses via such multifunctional system.

## II SYSTEM ARCHITECTURE

The power architecture of suggested grid supportive SPV system is demonstrated in Fig. 1. It consists of two power stages, which are the boost converter for MPPT and a three-leg grid tied VSC to transfer active power to a distribution system and to support it by providing harmonics mitigation, reactive power compensation and grid currents balancing. The connections of VSC and the distribution system are established via current smoothening inductors. The grid, smoothening inductors and shunt high pass filter are connected at a CCP. The shunt high pass filter absorbs the switching noise generated because of VSC. **CONTROL APPROACH**

The control of proposed system in terms of block diagram is presented in Fig. 2. The control approach consists of two main parts corresponding to two power converters. The control approach for boost converter generates duty ration such that the voltage across PV array reaches MPPT. The control approach for grid interfaced VSC maintains the balance of true power among the grid, load and VSC. The VSC acts as a three phase currents source in which currents for all the phases are adjusted such that the overall load reflection at CCP is a resistive. In order to achieve

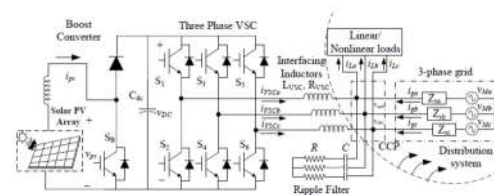

Fig: 1 System configuration

This objective, the VSC circulates the unbalanced currents to achieve grid currents balancing feature along with supplying inactive part of load currents. The control approach for both power converters are discussed here.

A. Control Approach for Boost Converter

An InC MPPT approach is used here [8]. The InC provides PV array voltage reference which finally generates reference duty cycle, using MPPT output and sensed output voltages of boost converter. The duty ratio to perform MPPT is as,

$$d_r(k) = 1 - \frac{V_{pvref}(k)}{V_{DC}(k)}$$

This duty ratio is used for calculation of pulse width for controlled switch of the boost converter.

B. Control Approach of Grid Connected VSC

The VSC is controlled as per block diagram shown in Fig. 2 (a). The CCP voltages ( $v_{sab}$ ,  $v_{sbc}$ ), grid currents ( $i_{ga}$ ,  $i_{gb}$ ), load currents ( $i_{La}$ ,  $i_{Lb}$ ), DC bus voltage ( $v_{DC}$ ), solar voltage ( $v_{pv}$ ) and current ( $i_{pv}$ ) are sensed and processed according to block diagram shown in Fig. 2. The overall control approach for complete system is shown in Fig. 2 (a). The phase voltages are estimated using sensed line voltages [22]-[23], which are then used to calculate the peak value using formula as follows,

$$\begin{bmatrix} v_{sa} \\ v_{sb} \\ v_{sc} \end{bmatrix} = \frac{1}{3} \begin{bmatrix} 2 & 1 \\ -1 & 1 \\ -1 & -2 \end{bmatrix} \begin{bmatrix} v_{sab} \\ v_{sbc} \end{bmatrix}$$

$$V_z = \sqrt{\frac{2(v_{sa}^2 + v_{sb}^2 + v_{sc}^2)}{3}}$$

The PV power contribution is incorporated in reference grid currents using feed forward term. The feed-forward term is based on PV array power and amplitude of CCP voltage. The simulation study for effect of PVFF term is shown in Appendix B. The reflection of PV array power on grid current is estimated in form of a feed-forward (IPVFF) term given as,

$$u_{zpa} = \frac{v_{za}}{V_z}, u_{zpb} = \frac{v_{zb}}{V_z}, u_{zpc} = \frac{v_{zc}}{V_z}$$

$$I_{PVFF} = I_{pv} = \frac{2P_{pv}}{3V_z}$$

An improved adjustable step adaptive neuron based approach is used to estimate the

contribution of load current in the grid currents. In the proposed approach, three neurons are used, one for each phase current. The three neurons are cross coupled to estimate average true power reflective part of load current. The governing equations are,

$$w_{pa}(n+1) = w_{pa}(n) + 2\sigma_p e(n)u_{zpa}$$

$$w_{pb}(n+1) = w_{pb}(n) + 2\sigma_p e(n)u_{zpb}$$

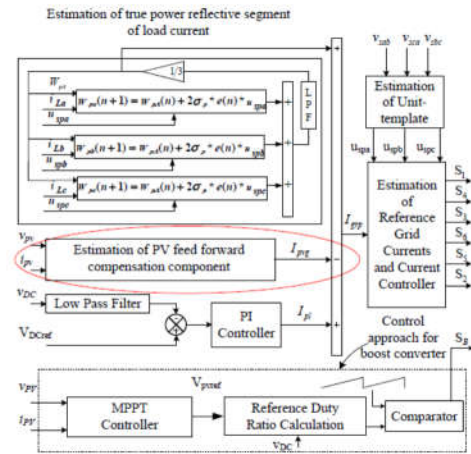

Fig 2 (a) Block diagram for control approach of the system

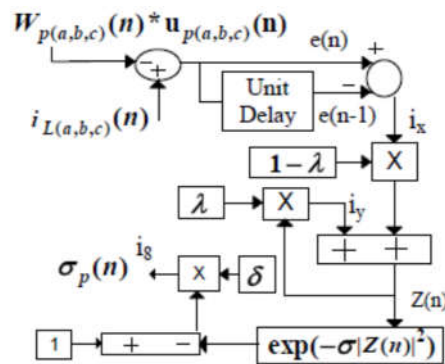

Fig 2 (b) Estimation of adaptive learning rate.

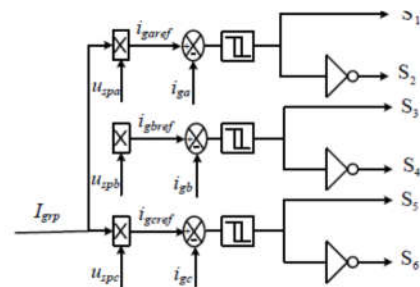

Fig 2. (c) Current controller

$$w_{pc}(n+1) = w_{pA}(n) + 2\sigma_p e(n)u_{sp}$$

where  $\sigma_p$  is the learning rate for the phase neurons. The learning rate for phase neurons is kept adjustable. The relation for keeping adjustable learning rate is as,

$$\sigma_p(n) = \delta(1 - \exp\{1 - \mu|z(n)|^2\})$$

$$z(n) = \lambda z(n-1) + (1 - \lambda)\{e(n) - e(n-1)\}$$

where  $e(n)$  and  $e(n-1)$  are difference between sensed and estimated output for corresponding phase.  $\delta$ ,  $\lambda$  and  $\mu$  are constants, which are selected as 0.4, 0.3, 0.5 respectively. The complete update law is shown in Fig. 2(b). The  $\sigma_p$  is adjusted according to load currents in order to keep the step size adjustable.

An average weight for cross coupling of neurons is estimated as,

$$w_{pA} = \frac{w_{pa} + w_{pb} + w_{pc}}{3}$$

The neurons are called cross coupled as the average neuron weight is used to estimate weight for each phase.

The loss fraction of the grid current is estimated by the help of a PIC (Proportional Integral Controller) on the DC link voltage of VSC. The output of PIC ( $I_{pl}$ ) is assumed as a loss component of the system as other two components are already estimated in feed-forward manner. Considering all three components, the amplitude of reference grid currents is estimated as,

$$I_{grp} = w_{pA} + I_{pl} - I_{pvG}$$

This  $I_{grp}$  is estimated amplitude true power part of uniformly distributed of grid currents. The three phase load power is distributed equally in three phases of grid while estimating amplitude of reference grid currents. Hence, reference grid currents estimated in this fashion are always balanced even in case when load draws unequal power from the three phases. The reference grid currents are estimated as,

The hysteresis current controller for grid currents decides the switching pattern for the VSC as shown in Fig. 2 (c).

### C. Approximate Model and Assessment of Improvements

A general representation of a conventional PV inverter with its control approach is shown in Fig. 3, wherein the sensed load currents are processed with the adjustable step neuron based technique. In this conventional approach, a PI controller is used to maintain the DC link voltage to the desired value. A close observation reveals that in this case, the output of PI controller consists of loss component of VSC and contribution of solar power in the grid current. Therefore, while setting the gains of the PIC there is a coupling in loss and solar power component. Since the contribution of the solar power changes throughout the day, the output of the PI controller varies in a wide range. Moreover, due to sudden cloud or change in climatic condition, the solar power contribution changes rapidly. Therefore, it is difficult to tune the DC link PIC to provide good steady state and dynamic performances under all operating condition. Therefore, in the proposed system, an extra term for contribution from solar array is derived using PV array power and sensed grid voltages. It should be noted here that no extra sensor is used to deduce this information. The PV array voltage and current are being already sensed for MPPT operation and the grid voltage for grid synchronization. The model for DC link voltage control loop is shown in Fig. 4, where the PIC bears the burden for loss and solar power contribution. However, the model for DC link voltage control for the proposed approach is shown in Fig. 5. It is clearly visible from the overall control loop in the Fig. 5 that the extra added solar array contribution cancels the PV array input power and the load term cancels the power drawn by the loads. Therefore, the feed-forward term instantaneously cancels effect of changes in the PV array power and the load power which leads to fast dynamic response and limited DC link voltage overshoot. These feed-forward terms also relieve the burden on the PIC such that the changes in the PV array power and load power are not dealt with the PI controller. Therefore, from DC link voltage control point of view, the burden on the PIC is reduced and it has to bear only the loss component of the power.

### III. DESIGN OF ADAPTIVE NEURO-FUZZY CONTROLLER

Adaptive neuro fuzzy inference system (ANFIS) integrates the best features of fuzzy systems and neural networks, and it has potential to capture the benefits of both in a single frame work. ANFIS is a kind of artificial neural network that is based on Takagi-sugeno fuzzy inference system, which is having one input and one output. Using a given data set, the toolbox function of ANFIS constructs a fuzzy inference system (FIS) where as the membership function parameters are tuned (adjusted) using a back propagation algorithm. In order to have an idea of optimized ANFIS architecture for proposed control, an initial data is generated from normal PI regulator and the data is saved in workspace of MATLAB. Then the ANFIS command window is opened by typing anfis editor in the main MATLAB window. Then the data previously saved in workspace is loaded in the ANFIS command window to generate an optimized ANFIS architecture as shown in Fig.3.

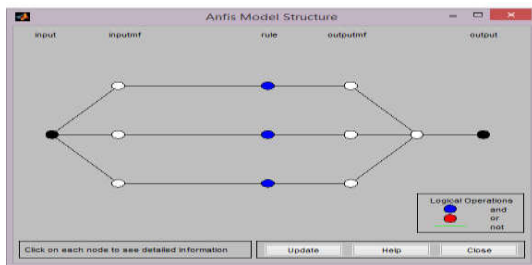

Figure. 3 Optimized ANFIS architecture suggested by MATLAB/anfiseditor.

In Fig.4 shows schematic of the proposed ANFIS based control architecture. The node functions of each layer in the ANFIS architecture are described as follows:

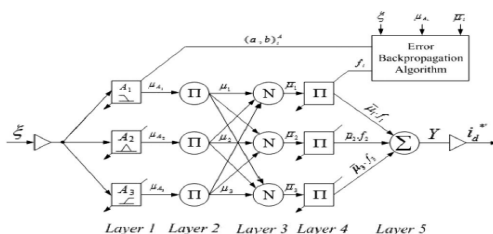

Figure. 4 Schematic of the proposed ANFIS-based control architecture.

The error between reference dc-link voltage and actual dc-link voltage ( $\xi = V_{dc}^* - V_{dc}$ ) is given to the neuro-fuzzy controller and the same error is used to tune the precondition and consequent parameters [10]. The control of dc-link voltage gives the active power current component ( $i_d^*$ ), which is further modified to take in account of active current component injected from RES ( $i_{Ren}$ ). The node functions of each layer in ANFIS architecture are as described below:

Layer 1: This layer is also known as fuzzification layer where each node is represented by square. Here, three membership functions are assigned to each input. The trapezoidal and triangular membership functions are used to reduce the computation burden as shown in Fig. 5. And the corresponding node equations are as given below:

$$\mu_{A1}(\varepsilon) = \begin{cases} 1 & \varepsilon \leq b_1 \\ \frac{\varepsilon - a_1}{b_1 - a_1} & b_1 < \varepsilon < a_1 \\ 0 & \varepsilon \geq a_1 \end{cases}$$

$$\mu_{A2}(\varepsilon) = \begin{cases} 1 - \frac{\varepsilon - a_1}{0.5b_2} & |\varepsilon - a_2| \leq 0.5b_2 \\ 0 & |\varepsilon - a_2| \geq 0.5b_2 \end{cases}$$

$$\mu_{A3}(\varepsilon) = \begin{cases} 0 & \varepsilon \leq a_3 \\ \frac{\varepsilon - a_1}{b_1 - a_1} & a_3 < \varepsilon < b_3 \\ 1 & \varepsilon \geq b_3 \end{cases} \quad (12)$$

where the value of parameters ( $a_i, b_i$ ) changes with the change in error and accordingly generates the linguistic value of each membership function. Parameters in this layer are referred as premise parameters or precondition parameters.

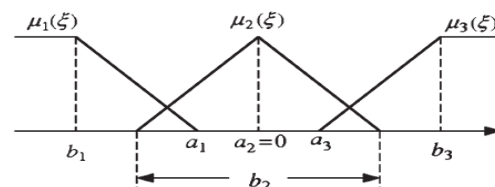

Figure. 5 Fuzzy membership functions.

Layer 2: Every node in this layer is a circle labelled as Pi, which multiplies the incoming signals and forwards it to next layer

$\mu_i = \mu_{Ai}(\varepsilon_1) \cdot \mu_{Bi}(\varepsilon_2) \dots i=1,2,3,\dots$  But in our case there is only one input, so this layer can be ignored and the output of first layer will directly pass to the third layer. Here, the output of each node represents the firing strength of a rule.

Layer 3: Every node in this layer is represented as circle. This layer calculates the normalized firing strength of each rule as given below:

$$\bar{\mu}_i = \frac{\mu_i}{\mu_1 + \mu_2 + \mu_3} \quad (13)$$

Layer 4: Every node in this layer is a node function

$$O_i = \bar{\mu}_i \cdot f_i = \bar{\mu}_i (a_0^i + a_1^i \varepsilon) \quad i=1,2,3.$$

where the parameters  $(a_0^i, a_1^i)$  are tuned as the function of input  $(\xi)$ . The parameters in this layer are also referred as consequent parameters.

Layer 5: This layer is also called output layer which computes the output as given below: The output from this layer is multiplied with the normalizing factor to obtain the active power current component.

#### IV MATLAB SIMULATION RESULTS

A prototype of the system is developed in the laboratory. The major equipments used in the experimental prototype are given in Table-I.

The steady state MPP efficiency is found around 99.5 % as shown in Fig. 6. Simulation results including equilibrium state and system dynamics condition are demonstrated in this section in order to validate the feasibility of the concept.

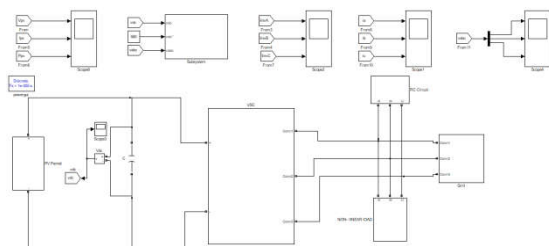

Fig.6 MATLAB SIMULINK model for the Proposed Grid Connected PV System with ANFIS

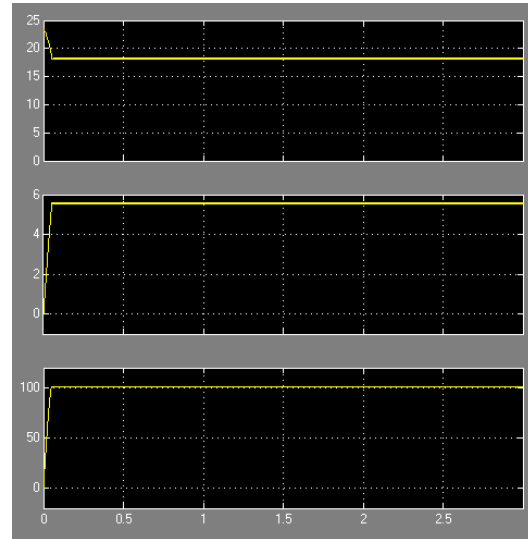

Fig 7 Solar parameters Voltage (V), Current (A), Power (W)

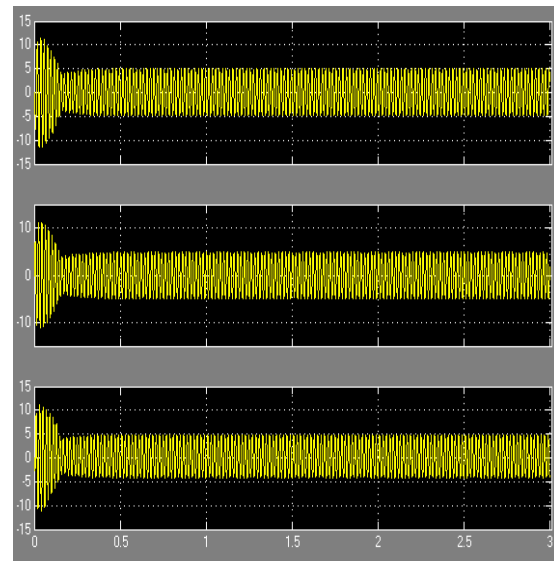

Fig 8 Line Current Iabc of the Proposed SPV with ANFIS Controller

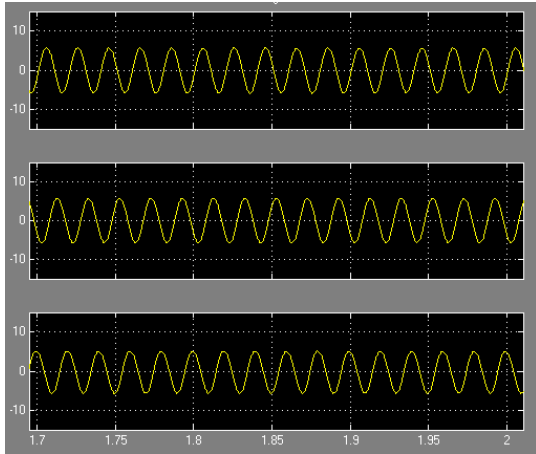

Fig 9 Source Current Isabc of the Proposed SPV with ANFIS Controller

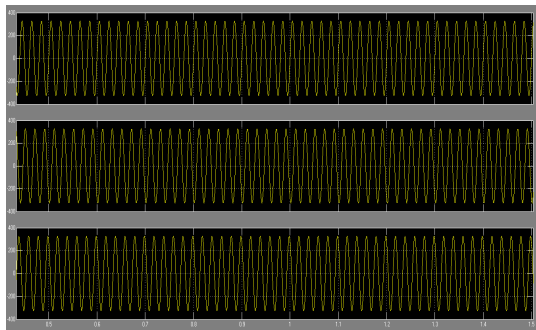

Fig 10 Source Voltage Vsabc of the Proposed SPV with ANFIS Controller

The equilibrium state and dynamic potentials of the system are shown in Figs. 7-13. The operation for load thrown at phase-c for three phase nonlinear load is connected at CCP is manifested using Fig. 7. The load line for phase-c is disconnected to emulate load transient and unbalanced load operations. Fig. 7 (a) shows CCP voltage ( $v_{sab}$ ) with grid currents. The grid currents before and after load disconnection are balanced and sinusoidal. The grid currents are increased after disconnection of load in order to feed same solar power however, with reduced load at CCP. Fig. 7 (b) shows three phase load currents, after load disconnection, the natures of

waveforms for other two phase currents are changed and current in phase c is zero. Fig. 7 (c) shows the VSC currents. Before load disconnection, the VSC currents are balanced and consist of load currents harmonics and fundamental active part corresponding

to the solar power. After load disconnection, since there are no harmonics in c-phase load, the VSC current changes to sinusoidal same as the grid current. Fig. 7(d) shows that load thrown does not have a significant effect on the DC link voltage and PV array parameters. Fig. 8 shows the effect of load inclusion on various voltages and current related to the system. A vice versa explanation of Fig. 7 can be given for corresponding parts of Fig. 8.

The solar PV array insolation changes in the full range during a day's time. Therefore, test results depicting dynamic performance for changes in insolation are important for characterizing quality of the system. In order to demonstrate behavior only with respect to insolation changes, the loads on the CCP are kept same throughout and only SPV insolation is varied. In this experimental study, the insolation is varied from 1000 W/m<sup>2</sup> to 500 W/m<sup>2</sup> and corresponding performance is shown in Fig. 9. The grid currents decrease uniformly even under running insolation changes as exhibited in Fig. 9 (a). The changes in solar insolation have no significant effect on load currents, as manifested in Fig. 9 (b). Fig. 9 (c) shows that the VSC currents decrease uniformly with a decrease in input PV array power. Fig. 9 (d) shows  $v_{pv}$ ,  $i_{pv}$ ,  $v_{DC}$  and  $i_{gc}$  wherein,  $v_{DC}$  is regulated irrespective of changes in the other system parameters. Fig. 10 shows the effect of an increase in insolation on various voltages and currents related to the system. A vice versa explanation of Fig. 9 can be given for corresponding parts of Fig. 10.

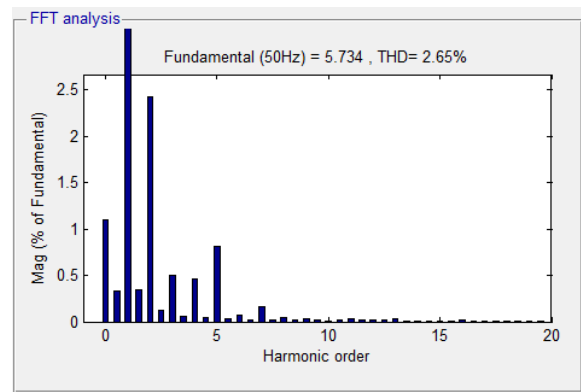

Fig 11 Source current THD (%) of the proposed SPV with ANFIS Controller

## CONCLUSIONS

A grid supportive SPV generation system with Adaptive Neuro Fuzzy Interface System (ANFIS) has been proposed for combined aim of distributed SPV generation and power quality improvement. An ANFIS approach has been proposed for control and verified by MATLAB/SIMULINK environment. A reduction in distribution losses can be achieved using these grid supportive PV systems on account of improved power quality. A corresponding case study for reduction in distribution losses is shown in section V. The prototype model is tested at Matlab Simulation with considerable power handling advocating the feasibility of proposed grid supportive distributed generation system.

## REFERENCES

- [1] N Y Dahlan, Mohd Afifi Jusoh and W N A W Abdullah, "Solar grid parity for Malaysia: Analysis using experience curves," *IEEE Power Engineering and Optimization Conference (PEOCO)*, 2014, pp.461-466.
- [2] S. Reichelstein and M. Yorston, "The prospects for cost competitive solar PV power special section: Long run transitions to sustainable economic structures in the European Union and beyond," *Energy Policy*, vol. 55, pp. 117–127, 2013.
- [3] S.B. Kjaer, J.K. Pedersen and F. Blaabjerg, "A review of single-phase grid-connected inverters for photovoltaic modules," *IEEE Trans. on Industry Applications*, vol.41, no.5, pp.1292-1306, Sept.-Oct. 2005.
- [4] Yang Chen and K.M. Smedley, "A cost-effective single-stage inverter with maximum power point tracking," *IEEE Trans. on Power Electronics*, vol.19, no.5, pp.1289-1294, Sept. 2004.
- [5] S. Anand, S. K. Gundlapalli and B. G. Fernandes, "Transformer-Less Grid Feeding Current Source Inverter for Solar Photovoltaic System," *IEEE Trans. Indus. Electron.*, vol. 61, no. 10, pp. 5334-5344, 2014.
- [6] Bidyadhar Subudhi and Raseswari Pradhan, "A comparative study on maximum power point tracking techniques for photovoltaic power systems," *IEEE Trans. Sus. Energy*, vol. 4, no. 1, pp.89-98, Jan. 2013.
- [7] M. A. Elgendy, B. Zahawi and D. J. Atkinson, "Evaluation of perturb and observe MPPT algorithm implementation techniques," *IET Renewable Power Generation Conference*, 2011, pp.1-6.
- [8] G. J. Kish, J. J. Lee and P. W. Lehn, "Modelling and control of photovoltaic panels utilising the incremental conductance method for maximum power point tracking," *IET Renewable Power Generation*, vol.6, no.4, pp.259-266, July 2012.
- [9] B. Singh, S. R. Arya, C. Jain, "Simple peak detection control algorithm of distribution static compensator for power quality improvement," *IET Power Electronics*, vol.7, no.7, pp.1736-1746, 2014.
- [10] B. Singh, S. R. Arya, C. Jain, S. Goel, "Implementation of four-leg distribution static compensator," *IET Generation, Transmission & Distribution*, vol.8, no.6, pp.1127-1139, 2014.
- [11] Chinmay Jain and Bhim Singh "A Frequency Shifter Based Simple Control for Multifunctional Solar PV Grid Interfaced System" *37th National System Conference*, 2013, pp 1-6.
- [12] Chinmay Jain and Bhim Singh "A Single-Phase Single-Stage Multifunctional Grid Interfaced Solar PV System under Abnormal Grid Conditions," *IET Generation, Trans. and Distribution*, vol.9, no.10, pp.: 886 - 894, 2015.
- [13] Chinmay Jain and Bhim Singh, "A Three-Phase Grid Tied SPV System with Adaptive DC Link voltage for CPI Voltage Variations," *IEEE Transactions on Sustainable Energy*, vol.7, no.1, pp.337-344, Jan. 2016.
- [14] C. Jain and B. Singh, "An Adjustable DC Link Voltage Based Control of Multifunctional Grid Interfaced Solar PV System," in *IEEE Journal of Emerging and Selected Topics in Power Electronics*, Early Access.
- [15] Chinmay Jain and Bhim Singh, "A PEF Based Control for Single-Phase Multifunctional SECS with Adaptive DC Link Structure for PCC Voltage Variations," in *Proc. of 30th Annual IEEE Applied Power Electronics Conference & Exposition*, 2015, pp. 1722-1729.
- [16] B. Singh, Chinmay Jain and Sagar Goel "ILST Control of Single-Stage Dual Purpose Grid Connected Solar PV System," *IEEE Transactions on Power Electronics*, vol.29, no.10, pp.5347-5357, 2014.



[17] Bhim Singh, Chinmay Jain, Sagar Goel, Ambrish Chandra and Kamal Al-Haddad, "A Multifunctional Grid Tied Solar Energy Conversion System with ANF Based Control Approach," *IEEE Transactions on Industry Applications*, Accepted for publication.

[18] S. Janpong, K.L. Areerak and K.N. Areerak, "A literature survey of neural network applications for shunt active power filters," *Journal of World Academy of Science, Engineering and Technology*, vol. 60, pp.392-398, 2011.

[19] Changhe Li, Zhengguo Wu and Fei Liu, "A Novel Variable Step size Adaptive Harmonic Detecting Algorithm Applied to Active Power Filter," *IEEE International Conference on Industrial Technology*, 2006, pp.574-578.

[20] B. Singh, C. Jain, A. Bansal, "An improved adjustable step adaptive neuron based control approach for grid supportive SPV system," in Proc. 2015 Annual IEEE India Conf. (INDICON), New Delhi, India, pp. 1 - 6.

[21] S.R. Arya, B. Singh, A. Chandra and K. Al-Haddad, "Control of DSTATCOM using adjustable step least mean square control algorithm," *IEEE 5th Power India Conference*, 2012, pp.1-6.

[22] Bhim Singh, Ambrish Chandra and Kamal Al-Haddad, *Power Quality: Problems and Mitigation Techniques*, John Wiley and Sons, UK, 2015, p.117.

[23] H. Akagi, E. H. Watanabe, and M. Aredes, *Instantaneous Power Theory and Applications to Power Conditioning*, John Wiley & Sons, Inc., Hoboken, NJ, 2007.

[24] IEEE Recommended Practices and requirement for Harmonic Control on Electric Power System, IEEE Std. 519, 1992.



**M.Asha** is studying her Post graduate degree in Anamacharya institute of Technology & Science (AITS) affiliated to Jawaharlal Nehru Technological University Anantapur in Electrical and Electronics Engineering with specialization in Power Electronics.



**V.E.Sowjanya** received the B.Tech. Degree in Electrical & Electronics Engineering from KSRM College of Engineering, Kadapa. Affiliated to Sv University Tirupathi, India in 2007 and the M.Tech. Degree in Power Electronics from G.Naranamma Institute of Technology Hyderabad Affiliated to

Jawaharlal Nehru Technological University Hyderabad, India in 2009. Currently, She is Working an Assistant Professor in Electrical & Electronics Engineering Department, AITS, Tirupati, India. Her research interests include Power Electronics and Simulation, Power Quality Monitoring and Control System.



**Dr.C.Sasikala** received the B.Tech. degree in Electrical & Electronics Engineering from S.V University, Tirupati, India in 1991. The M.Tech.degree in Electrical Power Systems from S.V University, Tirupati, India in 2002 and received the Ph.D. degree from the S.V University, Tirupati, India, in 2011. She was the Professor & Head of the Electrical & Electronics Engineering department with MITS Madanapalli and KL University from 2002 to 2015. Currently, She is working as professor & Head in the department of Electrical & Electronics Engineering, Annamacharya institute of Technology & Science (AITS), Tirupati, India. Her research interests include Distribution Systems, Power Systems Operation & Control, Power System Protection, Power System Analysis and Power Quality Monitoring & Mitigation.