

REVIEW OF DIGITAL TWIN SPARK IGNITION SYSTEM

S. NAKKEERAN¹, AJIT AMAN², SAURABH GIRI³, AMIT KUMAR⁴

¹Assistant Professor, Dept. of Mechanical Engineering, Bharath Institute Of Higher Education And Research, Chennai Tamil Nadu.

^{2,3,4}Final Year Student, Dept. of Mechanical Engineering, Bharath Institute Of Higher Education And Research, Chennai Tamil Nadu.

ABSTRACT

The latest trend of new generation is bikes and cars with new technology and high speed. Today it is a common trend. It has become a fashion for the people especially living in urban areas to ride such vehicles. Now the companies even want to launch such vehicles that attract the younger generation. This can be achieved by technology known as DTSi. Due to DTSi (digital twin spark ignition) system it is possible to combine strong performance and fuel efficiency. The improved engine efficiency modes have also resulted in lowered fuel consumption. DTSi delivered shattering performance and high levels of actual on-road fuel efficiency but bikes having DTSi system meet the Government of India's emission norms for 2005 right now itself without use of any secondary devices. Spark ignition is one of the most vital systems of an engine. Any variation in the spark timing and number of sparks per minute affects the engine performance severely. Thus a good design and control of the system parameters becomes most essential for optimum performance of an engine. Due to Digital Twin Spark Ignition system it is possible to combine strong performance and higher fuel efficiency. DTSi offers many advantages over conventional mechanical spark ignition system. In this paper we will get to know how mechatronics is useful in instrumentation.

Keywords: Efficiency, Less friction and wear, Less maintenance, Minimizes emission levels, New evolution, Proper engine's firing order.

I. INTRODUCTION

One of the requirements of an efficient engine is the correct amount of heat shock, delivered at the right time. This requirement is the responsibility of the ignition systems. The ignition system supplies properly timed high voltage surge to spark plugs. These voltage surges cause combustion inside the cylinder. The ignition system must create a spark or current flow across the each pair of spark plug electrodes at the proper instant, under all engine-operating conditions. This may sound relatively simple, but when one consider number of spark plug firing required and extreme variations in engine operating condition, it is easy to understand why ignition system so complex.[3]

If a 6-cylinder engine is running at 4000rpm, the ignition system must supply 12,000 sparks per minutes because ignition system must fire three spark plugs per revolution. These plugs firing must also occur at the correct time and generate correct amount of heat. If the ignition system fails to these things, fuel economy, engine performance, and emission level will be adversely affected.[2]

Purpose of ignition system:

For each cylinder in an engine system has three main jobs,

It must generate an electric spark they has enough heat to ignite the air/fuel mixture in the combustion chamber.

It must maintain the spark long enough to allow for the combustion of all the air and fuel in the cylinder. It must deliver the spark to each cylinder so combustion can begin at the right time during the compression stork to each cylinder.[2]

Ignition Timing

Ignition timing refers to the precise time spark occurs and is specified by referring to the position of the piston in relation with crankshaft rotation. Ignition timing reference marks can engine parts and on a pulley or flywheel to indicate the position of piston. Vehicle manufacturer specify initial or base ignition timing.

When the marks are aligned at TDC or 0, the position in the cylinder is at TDC of its compression stroke. Additional numbers on a scale indicates the number of degrees of crankshaft rotation before TDC or after TDC. In majority of engines, the initial timing is specified at a point between TDC and 20 degrees before TDC. [2] All ignition-timing changes are made in response to following primary factors.

Engine RPM

At higher RPMs, the crankshaft turns through more degrees in a given period of time. If combustion is to be completed by 10 degrees after TDC, ignition timing must occur sooner or advanced. However air/fuel mixture turbulence increase with rpm. This causes the mixture inside cylinder to turn faster. Increased turbulence requires that ignition must occur slightly later or be advanced.

Engine load

The load on engine is related to the work it must do. Driving up hills or pulling extra weight increases engine load. Under load , there is resistance on the crankshaft therefore the piston have a harder time moving through their stroke. This is evident by low measure vacuum during the heavy loads. Under light loads and with throttle plates partially opened, a high vacuum exists in the intake manifold. The amount of air/fuel mixture drawn in to cylinder and manifold is small. On compression this thin mixture produces less combustion pressure and combustion time is less. To complete combustion by 10 degrees after TDC, ignition time must be advanced. [1]

Firing order

The function of ignition system extends beyond timing the arrival of spark to a single cylinder. It must perform this task for each cylinder of the engine in specific sequence.

Each cylinder of an engine must power once in every 720 degrees of crankshaft rotation. Each cylinder must have power stroke at its own appropriate timing during its rotation. To make this possible the piston and rod are arranged in precise fashion. This is called as engine's firing order. The firing order is arranged to reduce knocking and imbalance problem. Because potential for this

knocking is determined by the design and construction of the engine, the firing order varies from engine to engine regardless of the number of cylinders used.

Basic Components Computer / Microprocessor

Computer is the main component of this system, which controls the spark timing. It continuously adjusts the spark timing to obtain optimum combustion at various operating conditions. The computer monitors the engine operating parameters with various sensors. Based on this input, the computer signals the ignition module to collapse the primary circuit to fire the spark plug.

The goal of computerized spark timing is to produce maximum engine power, top fuel efficiency and minimum emission level during all types of operating conditions. The computer does this by continuously adjusting ignition timing. The computer determines the best spark timing based on certain engine operating parameters such as crankshaft position, engine speed throttle position, engine coolant temperature, initial and operating or barometric pressure. Once the computer receives input from all these and other sensors, it compares the existing operating condition to information permanently stored or programmed into its memory. The computer matches the existing condition to a set of conditions stored in the memory, determines proper timing settings, and sends signals to the ignition module to fire the plugs.

The computer continuously monitors existing conditions, adjusting timing to match what its memory tells it is the ideal setting for those conditions. It can do this very quickly, making thousands of decisions in a single second. The control computer typically has the following types of information permanently programmed in to it.

Speed related spark advance

Load-related spark advance

Warm up spark advance

Special spark advance

Photoelectric sensor

The third type of crankshaft position sensor is photoelectric sensor. The parts of this sensor include light emitting diode, a light sensitive photocell and slotted disc called a light beam interrupter.

The slotted disc is attached to the distributor shaft. The LED and photocell are situated over and under the disc opposite to each other. As the disc rotates between LED and photocell, light from LED shine through the slots . The intermittent flashes of light are translated onto voltage pulse by the photocell. When the voltage signals occur, the control unit turns the primary circuit off. Causing the magnetic field in the coil to collapse and sending the surge of voltage to spark plug .

The photoelectric sensor sends a very reliable signal to the control unit, especially low engine speeds.

These units have been primarily used on Chrysler and Mitsubishi engines.[5]

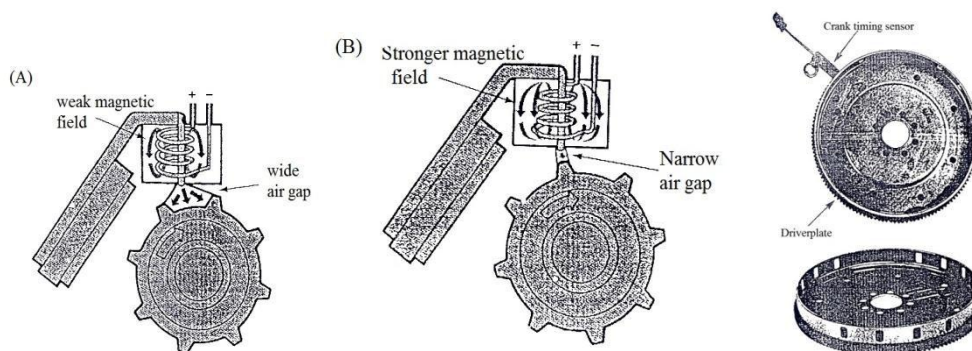

Fig.4.2.3 (A) Wide gap produces a weak magnetic field fig 4.2.3(B) Narrow gap produces a strong Magnetic field

fig. 4.2.3.1 Magnetic pulse generator positioned sense flywheel rotation

II. OPERATION

The ignition module is also responsible for limiting the dwell time. In EI system there is time between plug firing to saturate the coil. Achieving maximum current flow through the coil is great if the system needs the high voltage that may be available. However, if the high voltage is not needed, the high current is not needed and the heat it produces is not desired. Therefore, the control module is

programmed to only allow total coil saturation when the very high voltage is needed or the need for it is anticipated.

The ignition module also adjusts spark timing below 400 rpm (for starting) and when the vehicle's control computer bypass circuit becomes open or grounded. Depending on exact DSI system, the ignition coil can be serviced as a complete unit or separate unit. The coil assembly is typically called a coil pack and is comprised of two or more individual coils. On those DTSi system that use one coil per spark plug, the electronic ignition module determine when each spark plug should fire and controls the on/off time of each plug's coil. Due the way of the secondary coils are wired, when the induced voltage cutes across the primary and secondary windings of the coil, one plug fires in the normal direction positive center electrode to negative side electrode and the other plug fires the reverse side to center electrode. Both plugs fire simultaneously, completing the series circuit. Each plug fires the same way on both the exhaust and compression strokes.

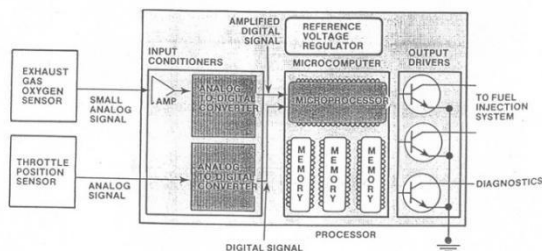

Fig5.1The A/D convertor prepared i/p signal for the CPU

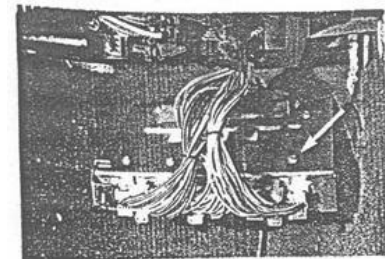

Fig 5.2 A typical automotive computer

The coil is able to overcome the increased voltage requirements caused by reversed polarity and still fired two plugs simultaneously because each coil is capable of producing up to 100,000 volts. There is very little resistance across the plug gap on exhaust, so the plug requires very little voltage to fire, thereby providing its mate (the plug is on compression) with plenty available voltage.

During starting only one plug is fired. Once the engine is running the other plug is located on the intake side of the combustion chamber, while the other is located on the exhaust side. Two coil packs are used, one for the plug on intake side and other for the plug on the exhaust side. These systems are called as duel plug system. During duel plug operation, the two coil packs are synchronized so each cylinder's two plug fire at the same time. The coil fires two spark plugs at the same time. Therefore,

on a 4-cylinder engine, four spark plugs are fired at a time; two during the compression stroke of the cylinder and two during the exhaust stroke of another cylinder.[4]

III. CONCLUSION

In the world of new high-speed cars and bikes to achieve maximum engine power, top fuel efficiency and minimum emission levels during all type of operating condition. The digital spark ignition is the best alternative for conventional ignition control. Computerized control gives accurate timing for all operating condition. At the same time use of two spark plug improves thermodynamic efficiency and power available.[3] At the same time it reduces the maintenance cost due to fewer moving parts in turn less friction and wear. It also good solution to reduce pollution since it minimizes emission levels. Also it is flexible enough in mounting location. This is important because today's smaller engine compartment. Thus, it is better in all areas like power, speed, efficiency and clean emission and hence it has brought a new evolution in automobile industry.[2]

IV. ACKNOWLEDGEMENT

In this paper, we would like to introduce the new technology in automobile sector, which plays important role in it. In the world of new high speed cars and bikes to achieve maximum engine power, top fuel efficiency and minimum emission levels during all type of operating condition. The digital spark ignition is the best alternative for conventional ignition control. Computerized control gives accurate timing for all operating condition. At the same time use of two spark plug improves thermodynamic efficiency and power available.

REFERENCES

- Automobile technologyl – A System Approach Third Edition by —JACK ERJAVECl Page No 533 to 563.
- Automobile Engineeringl Vol. 2-- By —KRIPALl Pg. No 516 to 607.
- OVERDRIVE –Vol. 6, No.1, September 2003. OVERDRIVE—Vol. 5, No 5, January 2003.
- IC Enginesl, Mathur and Sharma.

Braiding, Catherine R & Wardle, Mark (2012) "The Hall effect in star formation", Macquarie University, Australia <http://arxiv.org/abs/1109.1370>.

Keyence Corporation, —Multi-optical axis photoelectric sensor^l, [US7485841](#), 24 Jan 2008, 3 Feb 2009.