

# MEM CYCLE

## (Mechanical to electrical and electrical to mechanical cycle)

**Kumar R<sup>1</sup>, Karunesh G<sup>2</sup>, Santhosh Pavan Kumar<sup>3</sup>**

*1 (Student, CiTech, K R Puram, Bangalore, Karnataka, India-560036)*

*2 (Assistant professor, CiTech, K R Puram, Bangalore, Karnataka, India-560036)*

*3 (Assistant professor, CiTech, K R Puram, Bangalore, Karnataka, India-560036)*

### ABSTRACT

*This paper presents the design and fabrication of MEM CYCLE (Mechanical to electrical and electrical to mechanical cycle) model, recent days the fuel cost goes on hike day by day, the government is supporting the alternating fuel bikes to avoid the depletion of fuels and avoid environment air pollution finally global warming and this makes the idea and improving the existing electric bikes. In our project we designed the prototype model and fabrication of MEM cycle which works on 24 volts lead acid battery, we used 250 watts BLDC hub motor and a dynamo of the same capacity with fly wheel energy storing mechanism, so that regeneration of electrical energy. it is the dual powered weightless cycle works on electric motor and pedaling mechanism.*

**Keywords**–24V 17AH lead acid battery, 24V 250 Watt BLDC hub electric motor, 20 AH DC controller, etc

### I. INTRODUCTION

The present day scenario the fuel cost goes on hike day by day, the government is supporting the alternating fuel bikes to avoid the depletion of fuels and avoid environment air pollution finally global warming.[1] All variants of the bicycle over these years have subconsciously promoted the recreational use of bicycle and very less as a mode of transport. The most obvious reason for this is the comfort of the rider, time of travel, distance that can be covered that people get from fuelled vehicles, unlike the otherwise eco friendly bicycle.[3] [4]

MEM cycle is an effort towards just that. It allows the rider to commute in an eco friendly manner along with the reliability of a fossil fuelled vehicle in terms of refueling whenever required. Hence providing best of both towards worlds and to the rider. It is a successful combination of a flywheel, dynamo, batteries and motor and also the first of its kind to have no connection between pedals and the rear wheel. It is among those cycles which claim power generation on the go in addition to which power is being stored in this system.

MEM cycle is different from other flywheel cycles in terms of the following factors:

- This cycle being the first fusion of flywheel, motor and dynamo is also first of its kind to having no connection between the pedal and the rear wheel while still remaining a cycle.
- This cycle can be used as a complete motor driven vehicle as well with the assurance that there is always a backup power unlike most electric vehicles currently.

This project proposes a motorcycle which has dual sources. The motorcycle consists of two working power sources that are pedaling and electrical power driven BLDC 750 watt motor.

**1.1 LITERATURE SURVEY**

Aspects of the present disclosure involve an exercise bicycle in an indoor cycling configuration and including a US 9,044,635 B2 3 flywheel in an indoor cycling configuration. The exercise bicycle further includes an adjustable magnetic brake by which a rider may finely tune any resistive forces applied to the flywheel and thereby simulate different riding conditions. The magnetic brake is pivotally coupled with the frame such that magnets provided in a brake arm may be positioned relative the flywheel to induce more or less resistive power on the flywheel. Moreover, the brake arm is pivoted in such a way that normal forces applied to the brake arm by the interaction between the magnets and the flywheel will not pivot the brake arm and inadvertently increase resistance. [2] The exercise bicycle is configured for use by a variety of riders in club environment or for a single or limited number of riders in a home or other personal use environment.

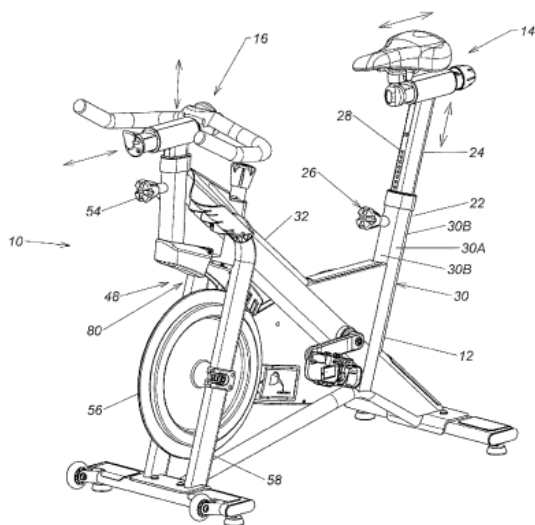

- |                              |                            |
|------------------------------|----------------------------|
| 12- Frame                    | 30- side walls             |
| 14- Adjustable seat assembly | 32- down tube              |
| 16- Handlebar assembly       | 48- front forks            |
| 22- Seat tube                | 52- handlebar post         |
| 24- Pop pin                  | 54- second popping         |
| 26- Pin                      | 56- flywheel               |
| 28- Apertures                | 58- opposing left fork leg |

We used the fly wheel mechanism for the constant mechanical power for regeneration of electrical energy.

**Fig 1** Exercise bicycle with magnetic flywheel

**II. DESIGN OF MEM CYCLE**

**1. Assembled 3D CAD drawing**

The prototype model is prepared in solid edge software advanced version, with proper proportions are shown below. The Fig.2 shows the assembled right view of the cycle. The transmission from pedal to flywheel can be seen

in the figure. Fig. 3 shows the left view of the assembled model, the flywheel frame to mount flywheel, battery frame to accommodate batteries and the dynamo placement can be seen.



Fig 2 Assembled model, right view



Fig 3 Assembled view, left view

## 2. The Transmission system

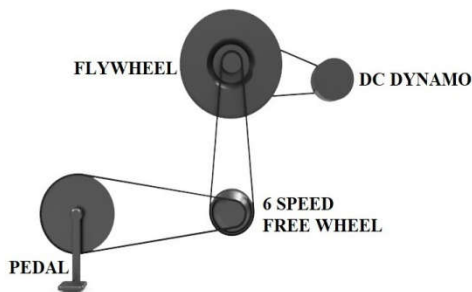

Fig 4 Schematic of transmission, front view



Fig 5 Schematic of transmission, top view

Fig.4 shows the basic transmission system adapted in the following project. The power expended by the rider at the pedals is transmitted to dynamo through flywheel by chains. Freewheels have been used to allow single direction rotation. Fig.5 shows the chain connections between pedal, flywheel and the dynamo.

### III. SELECTION OF MATERIALS

#### 1. Bicycle



**Fig 6** Hercules rebellio 619 model bicycle.

Specifications:

Brand Name: Hercules  
 Frame Size: 20 Inches  
 Brake Type: V Brake  
 Model Number: Rebellio 619 26"  
 Frame Material: Steel

#### 2. Flywheel



**Fig 7** Flywheel.

Specification:

Mass: 8kg  
 Diameter: 256.5 mm

#### 3. Dynamo



**Fig 8** Flywheel.

Specification of Dynamo:

Output Power: 250W.  
 Supply Voltage: 24V DC.  
 Speed: 2650 RPM.  
 No load speed: 3000RPM.  
 Full load Current:  $\leq 13.7A$ .  
 No load Current:  $\leq 2.2A$ .  
 Weight: 1.92 Kg.  
 Rated Torque: 0.80N-m (8 Kg-cm).  
 Stall Torque: 5 N-m (50 Kg-cm).  
 Efficiency  $\geq 78\%$ .

#### 4. Batteries

Specification:

Rating: 12V 17Ah  
 Type: Sealed lead acid  
 Quantity used: 4 numbers



**Fig 9** Dry lead acid rechargeable battery.

#### 5. Hub motor

Specification:

Rating: 24V 250W  
 Position: front wheel



**Fig 10** Hub motor.

#### IV. FABRICATION

1. Flywheel Frame:

Two, 3mm thick rectangular plates of dimensions 460\*192 mm were bought and holes were drilled



2. Components of flywheel assembly.



3. Freewheel with hub.



4. Flywheel axle.



5. Flywheel assembly.



6. Dynamo assembly.



### III. WORKING PRINCIPLE AND FINAL ASSEMBLED MODEL

In the following project, MEM basically stands for Mechanical to Electrical and back to Mechanical i.e., initial mechanical energy supplied by the rider is converted to electrical energy by the dynamo which again is converted into Mechanical energy by the motor. Hence the project is based on the “conservation of energy” on the whole, stating “energy can neither be created nor be destroyed, it can only be converted from one form to another”. For these conversions, MEM cycle is incorporated with a flywheel, a dynamo and a dc motor as its main energy conversion elements.

#### **Dynamo assembly:**

The dc motor bought to be used as dynamo for the project had an inbuilt gear of 11 teeth. Considering the gear ratios required, a gear of 16 teeth was attached after removing the existing gear. The dynamo base is attached to a metal structure of dimension 130\*100\*76 mm in order to be able to fix it to the rectangular base plate. The gear of the dynamo is to be perfectly aligned to the chain wheel of the flywheel assembly in order to transmit the power from flywheel to dynamo with the help of chain.

#### **Power transmission:**

The power transmission from pedals to flywheel and further from flywheel to the dynamo is all done by roller chains. A total number of 3 chains are used in the following project. First chain transmits muscle power of rider to the rear wheel, second chain transmits power from rear wheel chain wheel to the flywheel and the third chain transmits rotational energy of flywheel to the dynamo.

#### **Electrical assembly:**

Electrical assembly consists of the hub motor, motor controller, electric brakes, dynamo and the batteries. It includes all the necessary connections between batteries, dynamo and the hub motor. [4]

The dynamo is connected in series with a diode in its positive terminal and further connected to the batteries. Diode blocks the backflow of current, thus enabling the use of motor as a dynamo hence charging the battery.

The three batteries are connected in series so as to add up the voltages to obtain 24V of output. The 24V is supplied to the motor controller from where power is supplied to the hub motor.[3]

The DC motor controller is connected to hub motor, led indicator, power supply, electric brakes and throttle.

The MEM cycle After all the electric connections and mounting of all parts , it was time to finish up the bike by fixing small elements like seat, accelerator, mudguards, etc. After all parts were assembled, we tested every single aspect of the bike to know if any changes were required and error proof the bike.

Elements like speed, pick-up, comfort and charging were tested.



(a)

(b)

**Fig 11 (a) & (B) Assembled view of MEM cycle.**

#### IV. CONCLUSION

Successful fabrication of pedal assistance MEM cycle, the charging time of the battery pack is 4-6 hours, the cycle a gives 50 plus Kms per charge without pedaling at the speed of 30 KMPH without peddling.

#### REFERENCES

- [1] Karunesh G, Vignesh B, MolakaRavindra Kumar, “Design and fabrication of lithium ion battery pack pedal assistance electric bike” International Journal of Management, Technology And Engineering, ISSN NO : 2249-7455, Volume 8, Issue X, OCTOBER/2018, Page No:372.
- [2] Vivek V Kumar, Karthik A, Ajmal Roshan3, Akhil J Kumar, “Design and Implementation of Electric Assisted Bicycle with Self Recharging Mechanism”, 2014, 2319 – 8753.
- [3] KunjanShinde, “Literature review on electric bike”, 2017, 2249-5762.
- [4] Yashwant Sharma, Praveen Banker, YogeshRaikwar, YogitaChauhan, Madhvi Sharma, “R&D ON ELECTRIC BIKE”, 2018, 2395-0056.