

# INTELLIGENT OPTIMIZING TRAFFIC LIGHT AND DENSITY CONTROL USING IR SENSORS AND MICROCONTROLLER

**K. Sudheer Kumar<sup>1</sup>, Dr. C Rajasekaran<sup>2</sup>**

Associate Professor<sup>1</sup>, Professor<sup>2</sup>

Dept of ECE<sup>1,2</sup>

BITS, Adoni Kurnool (DT), Andhra Pradesh<sup>1</sup>

Anna University, Chennai<sup>2</sup>

**Abstract:-** Nowadays congestion in traffic is a serious issue. The traffic congestion can also be caused by large Red light delays, etc. The delay of respective light is hard coded in the traffic light and it is not dependent on traffic. Therefore for simulating and optimizing traffic control to better accommodate this increasing demand is arises. In this paper we studied the optimization of traffic light controller in a City using microcontroller. Thus I propose multiple traffic light control and monitoring system. The system tries to reduce possibilities of traffic jams, caused by traffic lights, to an extent. The system is based on microcontroller. The microcontroller used in the system is 89V51RD2 which is MCS-51 family based. The system contains IR transmitter and IR receiver which are mounted on the either sides of roads respectively. The IR system gets activated whenever any vehicle passes on road between IR transmitter and IR receiver. Microcontroller controls the IR system and counts number of vehicles passing on road. Microcontroller also store vehicles count in its memory. Based on different vehicles count, the microcontroller takes decision and updates the traffic light delays as a result. The traffic light is situated at a certain distance from the IR system. Thus based on vehicle count, microcontroller defines different ranges for traffic light delays and updates those accordingly.

The system records vehicle count in its memory at user predefined recording interval on real time basis. This recorded vehicle count data can be used in future to analyze traffic condition at respective traffic lights connected to the system. For appropriate analysis, the recorded data can be downloaded to the computer through communication between microcontroller and the computer. Administrator sitting on computer can command system (microcontroller) to download recorded data, update light delays, erase memory, etc. Thus administrator on a central station computer can access traffic conditions on any approachable traffic lights and nearby roads to reduce traffic congestions to an extent. In future this system can be used to inform people about different places traffic condition.

**Keywords—** IR (infrared) sensor, Image processing, Microcontroller, Digital Display.

## Introduction

Traffic research has the goal to optimize traffic flow of people and goods. As the number of road users constantly increases, and resources provided by current infrastructures are limited, intelligent control of traffic will become a very important issue in the future. However, some limitations to the usage of intelligent traffic control exist. Avoiding traffic jams for example is thought to be beneficial to both environment and economy, but improved traffic-flow may also lead to an increase in demand. There are several models for traffic simulation. In our research we focus on optimization of traffic light controller in a city using IR sensor and developed visual monitoring using microcontroller 89V51RD2.

Traffic light optimization is a complex problem. Even for single junctions there might be no obvious optimal solution. With multiple junctions, the problem becomes even more complex, as the state of one light influences the flow of traffic towards many other lights. Another complication is the fact that flow of traffic constantly changes, depending on the time of day, the day of the week, and the time of year. Roadwork and accidents further influence complexity and performance. In this paper, we propose two approaches, the first approach - to take data/input/image from object/subject/vehicle and in the second approach - to process the input data by Computer and Microcontroller and finally display it on the traffic light signal to control the Closed Loop System.

## Modeling Circuit

In this section, we focus on the use of IR sensor and wireless N/W in traffic control. A lot of ground can be gained in this area, and intelligent traffic control gained interest of several governments and commercial companies. ITS research includes in-car safety systems, simulating effects of infrastructural changes, route planning, optimization of transport, and smart infrastructures. Its main goals are: improving safety, minimizing travel time, and increasing the capacity of infrastructures. Such improvements are beneficial to health, economy, and the environment, and this shows in the allocated budget for ITS.

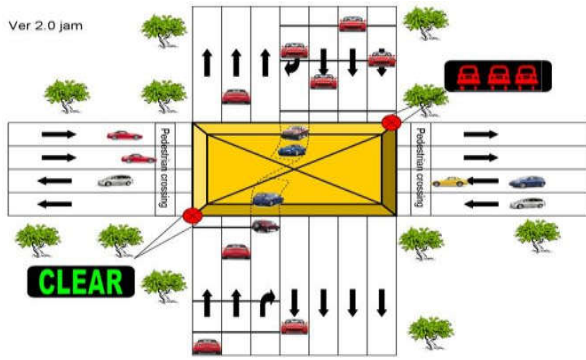

Figure 1 Traffic system for multiple road.

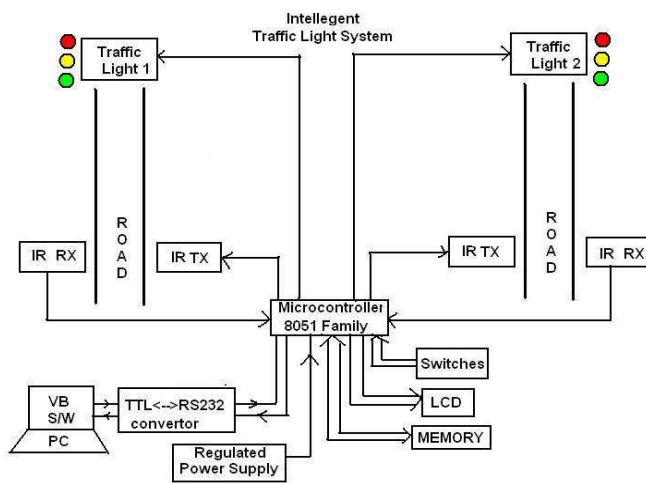

Figure 2 Block Diagram of system

## Design and development of the system

Development of the complete intelligent traffic light control and monitoring system includes lots of study and implementation work. The implementation work of the complete data logger is divided into points discussed below.

**Power Supply:** As per the power requirement of the hardware of the intelligent traffic light control and monitoring system, supply of +5V w.r.t GND is developed as shown in Figure 3.

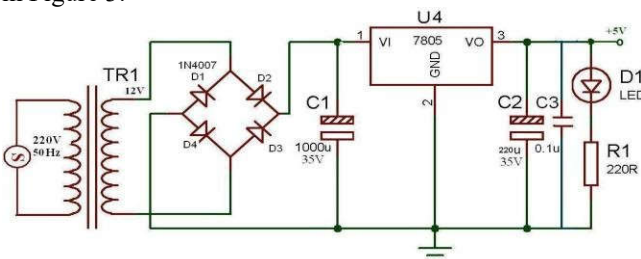

Figure 3 Circuit Diagram of Power Supply

The complete circuitry is operated with TTL logic level of 0-5V.. It comprise of 0V to 9V transformer to step down the 220V AC supply to 9V AC. Further a bridge rectifier converts the 9V into  $9\sqrt{2}$  DC. It is further filtered through a 1000uF capacitor and then regulated using 7805 to get +5V. To isolate the output voltage of +5V from noise further filtering 220uF capacitor is done.

## Circuit Diagram

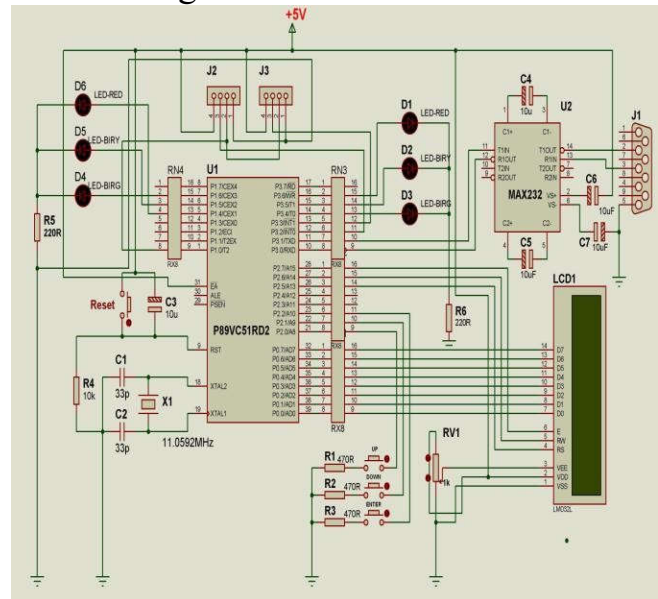

Figure 4 Circuit diagram of microcontroller board

The circuit shown in the Figure 4 is complete circuit diagram of intelligent traffic light control and monitoring system which shows the interfacing of some peripherals and ICs with the microcontroller P89V51RD2. This circuit is made in the software Proteus, which is basically a circuit making and simulation window based software. Microcontroller receives the 11.0592MHz from the crystal oscillator at XTAL1 and XTAL2 pin. Reset switch connected at pin 9 of microcontroller provide manual reset of the microcontroller. Pull-up network resistances of 10K are provide at each port to properly differentiate between high and low TTL signal. LCD connected with its three control signal RS (Resister Select), R/W (Read/Write) and E (Enable) is used to display the outputs and status messages for the user. Port P0 is used to provide data to LCD to display as character. RV1 potentiometer controls the contrast of LCD.

The intelligent traffic light control and monitoring system stores the recorded sample into its flash memory through its feature of In-Application programming. Data is stored with the real time and data stamp with it. This real time and date is provided by the user.

Microcontroller transfers the recorded data to the computer by serial communication through MAX232. This data is used for traffic monitoring by the user sitting on the computer. To interface the UART and PC RS32 all the nine outputs are connected through MAX232 IC for the signal conversion. Whole data transfer protocol is implemented through software discussed later in this chapter. Software in visual basic on computer end collects all recorded data. Three push button switches for UP, DOWN and ENTER are interfaced to microcontroller at respective pins of port P2. These switches are used for accept some numeric inputs from user for proper function of software of the system.

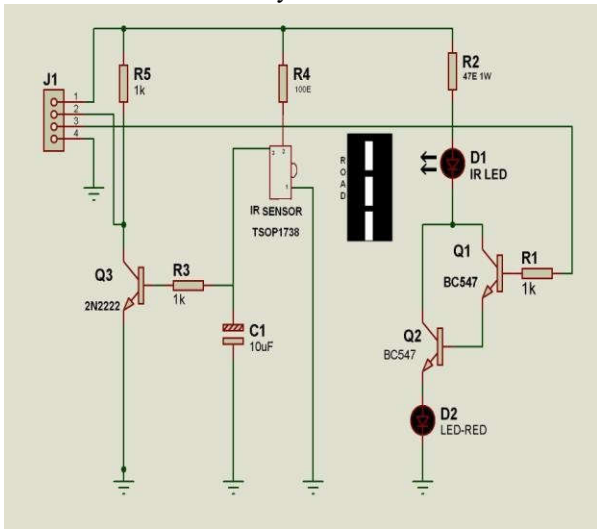

Figure 5 Circuit Diagram of Sensor on road

Figure 5 shows circuit diagram of IR transmitter and IR sensor situated on road. The system made here monitor and control the traffic movement for two roads respectively. Connector J1 and J2 of microcontroller board connects the IR sensor on road with the microcontroller board. Pin P1.0 from port P1 drives the IR transmitter by generating 38KHZ 50% duty cycle square wave. The IR sensor output is connected to pin P3.2 and P3.3 for both traffic light respectively. P1.0 control the IR LED D1 through Darlington pair formed by transistor Q1 and Q2. The Darlington pair just amplifies the current through IR LED. The IR sensor TSOP1738 detects the IR wave from IR LED and provides active low output at its pin3. SO whenever any vehicle passes through IR LED and IR sensor, the TSOP1738 provide high output at its pin3.

This obstacle in light is detected by the microcontroller. Signal from IR sensor is amplified by Q3 transistor.

## Development of Software of Intelligent Traffic Light Control and Monitoring System

### Assembler:

Assembler is used to convert the assembly language code to machine code. A51 assembler is used for this purpose. Figure 6 shows the A51 assembler GUI.

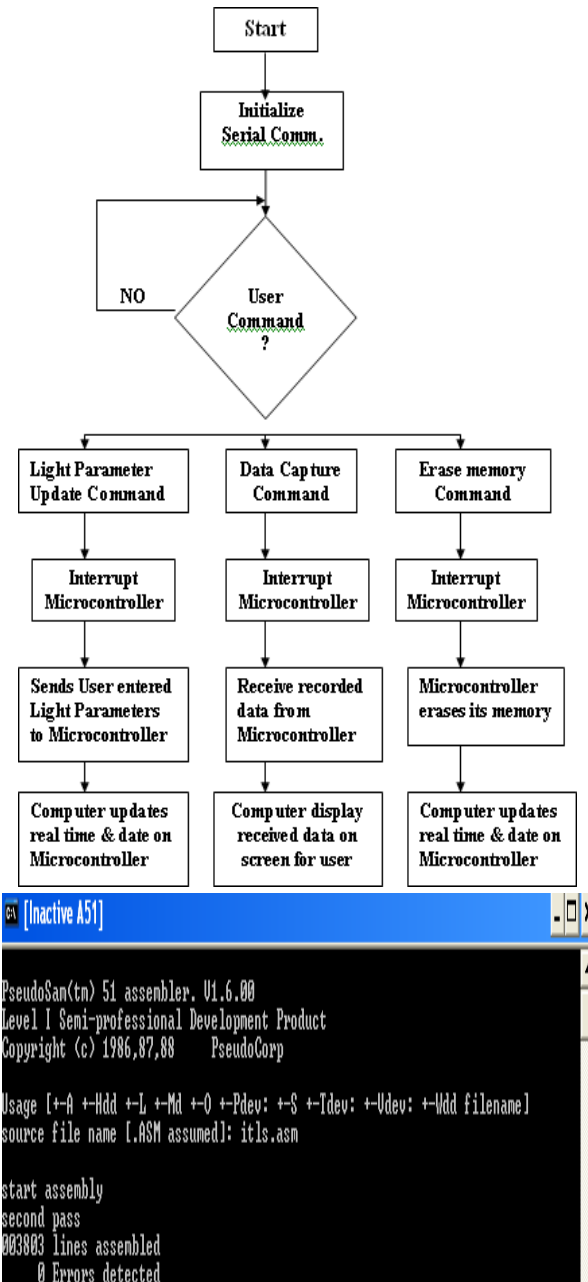

Figure 6 : Assembler GUI

### In-System Programmer:

P89V51RD2 microcontroller has the feature of In-System programming. Due to this it do not require any separate hardware programmer to get program. It includes an inbuilt boot program, which helps it in programming, erasing and in-application programming. The object code formed by the assembler or cross compiler is loaded into the software called IN-System programmer. Figure 7 shows a Flash mag- ic in system programmer. This window based programmer communicates with the microcontroller boot program through serial port.

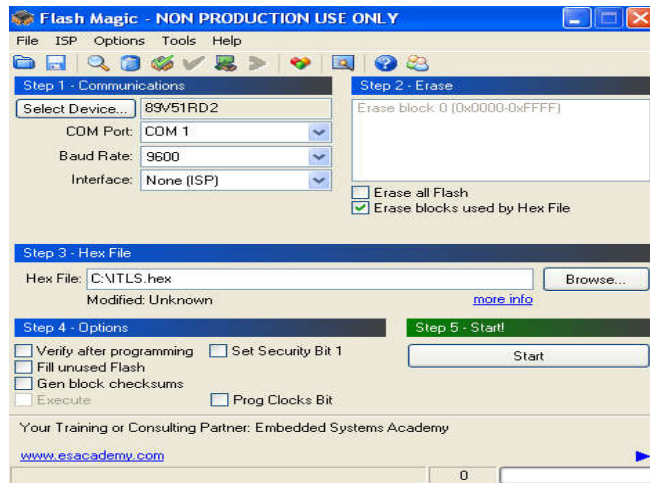

Figure 7 In-system Programmer GUI

### Computer Software:

The computer software for recorded data monitoring and system control is made in visual basic. The flowchart of the VB program is given below. Data transfer is initiated from computer through a user click in Visual Basic, which in turn requests the microcontroller serially. The microcontroller during its main loop continuously pools the serial port, as shown in flow chart. Microcontroller after getting the data transfer request from PC suspends its recording task temporarily and switches to data transfer mode. 9600 baud rate is used in the communication. Serial port communication parameters are initially configured for 9600 baud rate, 8 bit data word, no parity, and 1 stop bit.

### Results

Results include the successful operation of the intelligent traffic light control and monitoring system. The IR sensor with IR transmitter is placed at a gap. Gap acting as a prototype indicating a road. The system is placed near road as a stand alone device. Whenever any obstacle like vehicle

passes between IR transmitter and IR sensor, microcontroller detects and increase number of vehicle count in a recording interval for particular traffic light. Traffic light is placed ahead of IR sensor at a distance so that decision taken by microcontroller to control traffic light can help in reducing the congestion at traffic light.

On the basis vehicle count microcontroller decide the traffic light delays for next recording interval. Traffic light delays are classified as LOW, MEDIUM, HIGH range. These ranges are predefined by varying vehicle count.

Microcontroller display shown in figure 8 shows its operation.



Figure 8: Microcontroller display at time of system running

The L1 and L2 indicate the traffic light whose output user at system want to view. Next character current light activated on traffic light. Next time in seconds indicate elapses time for current light. Next three characters show current mode of traffic light delay. This mode depends on the previous vehicle count calculated in predefined recording interval.

Second line of display start with display running time of the system. Next is shown the vehicle count counted by the microcontroller from IR sensor for respective traffic light. This count is for current recording time. After completion of recording interval, this count value is saved in flash memory for further analysis.

The microcontroller is connected to computer through a serial communication cable. Through the cable user sitting on the computer as traffic administrator can command the microcontroller system to send the recorded data for monitoring. For the basis of data of traffic at respective load, where sensor is situated, can update the timings of traffic light delays with an updating command to microcontroller. Administrator can also send command microcontroller to erase previous recorded data after analysis. Below figure 9 shows the graphical user interface for administrator.

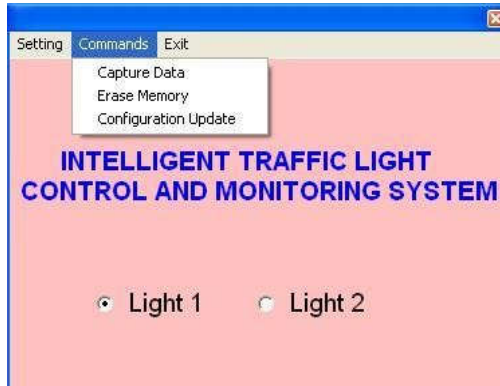

Figure 9 GUI of computer software

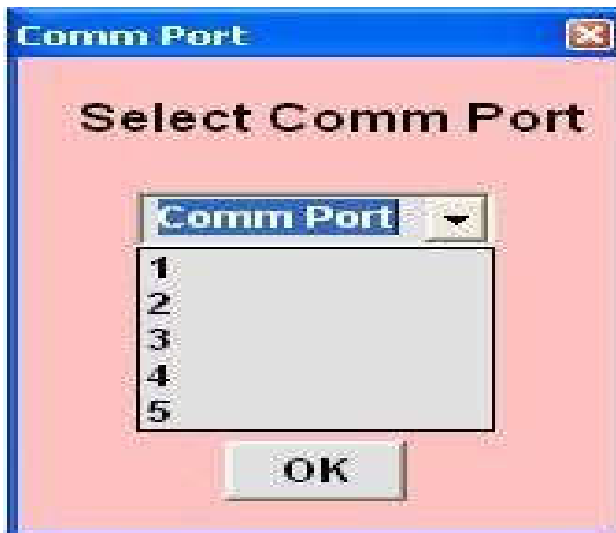

Figure 10 Communication port selection

To initiate the serial communication administrator has to configure the Communication port as shown in figure 10. Whenever administrator command microcontroller to send recorded data, the microcontroller send al data, as vehicle count recorded on basis of recording interval, to computer. The microcontroller also sends s the running configuration of parameters (Vehicle range values, delays, recording inter- val) on traffic light. The data can be saved on the computer as a excel file. The real time data for analysis is shown on computer as shown in figure 11.

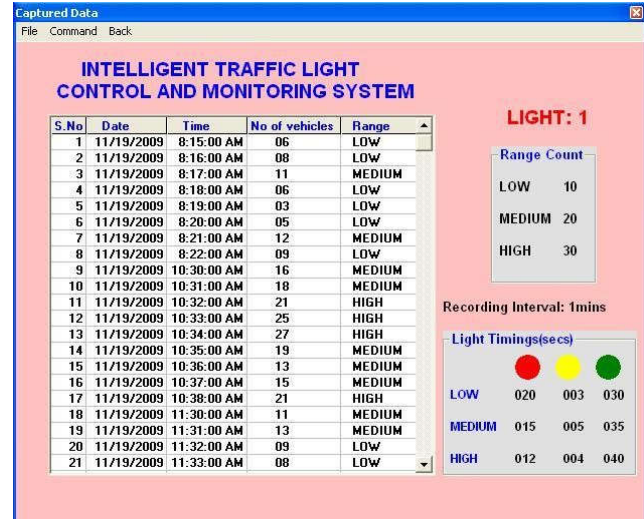

Figure 11 Capture data from microcontroller on computer screen

On basis of analysis administrator can command the microcontroller of update the configuration of parameter to respective lights. The graphical user interface to update configuration is shown in figure 12

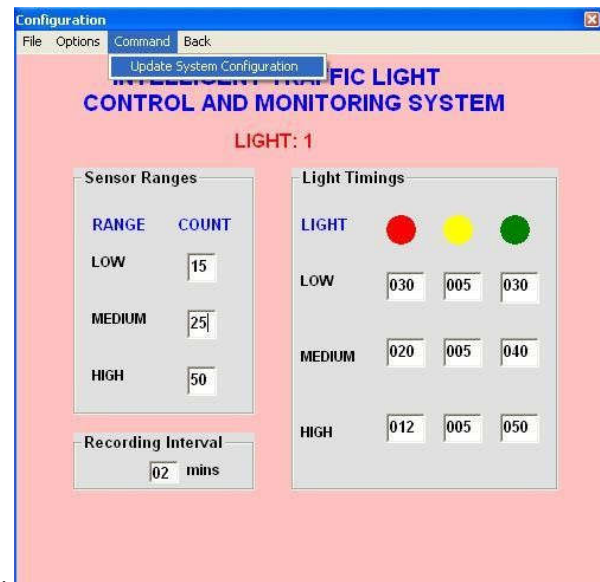

Figure 12 Configuration GUI on computer

## Conclusions and Future Scope

In this paper we have studied the optimization of traffic light controller in a City using IR sensors and microcontroller .Figure2 shows the basic block diagram of the system and figure-4. shows the complete circuit diagram of microcontroller board. By using this system configuration we tries to

reduce the possibilities of traffic jams, caused by traffic lights, to an extent and we have successfully gets the results. No. of passing vehicle in the fixed time slot on the road decide the density range of traffics and on the basis of vehicle count microcontroller decide the traffic light delays for next recording interval as shown in figure 8 and figure 12 .The recorded data can be downloaded to the computer through communication between microcontroller and the computer and this is shown in Figure11. The Administrator sitting on computer can command system (microcontroller) to download recorded data, update light delays, erase memory, etc. Thus administrator on a central station computer can access traffic conditions on any approachable traffic lights and nearby roads to reduce traffic congestions to an extent.

In future this system can be used to inform people about different places traffic condition. data transfer between the microcontroller and computer can also be done through telephone network , data call activated SIM This technique allows the operator to gather the recorded data from a far end to his home computer without going there. Traffic lights can be increased to N number and traffic light control can be done for whole city by sitting on a single place.

## Reference

- [1] Ramón Martínez “Smart control system for LEDs traffic-lights based on PLC”. Dpt. de Señales, Sistemas y Radiocomunicaciones. Universidad Politécnica de Madrid ETSI de Telecomunicación. Ciudad Universitaria s/n.28040 Madrid SPAIN
- [2]. Bechrakis D. A., Sparis P. D.” A flexible data logging device for wind potential measurements and statistical magnitudes”. Democritus university of Thrace, department of electrical and computer engineering, mechanical engineering laboratory, xanthi, 67 100, Greece
- [3] Muhammad Ridwan. „Development of a Low Cost Smart Traffic Controller System”. Department of Mechanical and Materials Engineering Faculty of Engineering and Built Environment Universiti Kebangsaan Malaysia, 43600 Bangi Selangor, Malaysia
- [4] Marco Wiering. “Intelligent Traffic Light Control”. Institute of information and computing sciences, utrecht university
- [5] W. Wen & C. L. Yang. “A dynamic and automatic traffic light control system for solving the road congestion problem”.
- [6] Cihan Karakuzu. “Fuzzy logic based smart traffic light simulator design and hardware implementation”. Kocaeli University, Engineering Faculty, Electronics & Tell. Eng. Department, 41070 Veziroglu Yerleskesi, Izmit-Kocaeli, Turkey
- [7] Cihan Karakuzu. “Fuzzy logic based smart traffic light simulator design and hardware implementation”. Kocaeli University, Engineering Faculty, Electronics & Tell. Eng. Department, 41070 Veziroglu Yerleskesi, Izmit-Kocaeli, Turkey
- [8] Kok, Khiang Tan and Marzuki. “Intelligent Traffic Lights Control by Fuzzy Logic”. Malaysian Journal of Computer Science
- [9] István Varga. “Design of an Intelligent Traffic- Control System”. Balázs Kulcsár, István Varga, SZTAKI, Hungary
- [10] A (Mildly) Intelligent Traffic Light System (a Bluespec tutorial)
- [11] “Automatic Traffic Control System”. SMEU Astana Solutions Automatic Traffic Control System.htm
- [12] P89V51RD2 specification sheet. “Microcontroller with 64K Bytes Flash Memory”. [Online] Available [www.philips/devices/microcontroller.com](http://www.philips/devices/microcontroller.com)
- [13] Multiple Traffic Control Using Wireless Sensor and Density Measuring Camera *Amrita Rai and Govind Singh Patel. Sensors & Transducers Journal Vol. 94, Issue 7, July 2008, pp. 126-132*